

ML7999A Universal Parallel-Positioning Actuator

PRODUCT DATA



FEATURES

- Universal power supply input.
- Password protected with an eight-digit hexadecimal identification signal.
- 100 lb-in. (11.3 Nm) torque.
- Includes integral position feedback potentiometer.
- Separate wiring compartment between line voltage power wiring and low voltage control.
- Direct coupling shaft interface mounting.
- Couples directly to a 1/2 in. (13 mm) shaft with no additional parts required.
- Couples directly to 5/16 in. (8 mm) and 3/8 in. (9 mm) shafts using available self-centering shaft reduction accessories.
- Shaft coupler assembly available for shafts larger than 1/2 in.
- Bracket Accessory Kit available for mounting to Honeywell V51 Butterfly Gas Valves.

APPLICATION

ML7999A Universal Parallel-Positioning Actuator provides 100 lb-in. torque, pulse-width-modulating (PWM) control of combustion air dampers, butterfly gas valves, oil modulation valves, and flue gas recirculation systems. The actuator includes a precision feedback potentiometer and integral power supply capable of direct line voltage connection. The ML7999A Actuator is part of the Fuel-Air-Ratio Control System, and must be used with the R7999 Fuel-Air-Ratio Controller.

Contents

Application	1
Features	1
Specifications	2
Ordering Information	2
Installation	3
Wiring	4
Operation	5
Checkout and Troubleshooting	6



SPECIFICATIONS

Model:

ML7999A Universal Parallel-Positioning Actuator. Medium torque electronic actuator with a precision feedback potentiometer and integral power supply capable of direct line voltage connection.

Dimensions:

See Fig. 1.

Electrical Ratings:

Power Input: 100 to 240 Vac +10% -15%, 50/60 Hz.
Maximum Power Consumption: 15 VA.

IMPORTANT

Device must be hardwired.

Temperature Range:

Ambient: -40°F to +140°F (-40°C to +60°C).
Storage: -40°F to +150°F (-40°C to +65°C).

Humidity Range (at 95°F [35°C]):

5 to 95 percent relative humidity, noncondensing.

Vibration:

0.0 to 0.5g continuous (V2 level).

Control Signal (at 5 mA current):

Drive Clockwise: Minimum 4.25 Vdc differential between DR1-DR2.
Drive Counterclockwise: Maximum -4.25 Vdc differential between DR1-DR2.

NOTE: Actuator does not respond until the 8-digit ID signal from the R7999 is passed via DR1-DR2.

Actuator Stroke:

95° nominal ± 3°, mechanically limited.

Output Hub Position Accuracy:

±0.1°.

Torque Ratings at Rated Voltages:

Lift and Hold Minimum: 100 lb-in. (11.3 Nm).
Breakaway Minimum: 100 lb-in. (11.3 Nm).
Stall Minimum: 100 lb-in. (11.3 Nm).
Stall Maximum: 150 lb-in. (17 Nm).

Actuator Design Life (at 100 lb-in.):

Full-Stroke Cycles: 100,000 minimum.
Repositions: 2,000,000 minimum.

Feedback Potentiometer:

Total Resistance: 5000 ohms ±10%.

Actuator Timing (90° Travel):

Standard: 24 to 30 seconds.
Derated Cold-Start Timing (from -40°F to -20°F (-40°C to -29°C): 150 seconds maximum.

Noise Rating:

55 dBA maximum at 1m during normal operation.

Mounting:

Mounts directly on 1/2 in. (13 mm) round or square shaft. With proper accessories, mounts to 5/16 in. and 3/8 in. (8 mm, 10 mm) round or square shafts; 9/16 in., 5/8 in., and 3/4 in. (14 mm, 16 mm, and 19 mm) round shafts.

IMPORTANT

Tighten hub setscrews to a torque of 60 lb-in. ±10 lb-in.

Position Indicator:

Visible with cover on device.

Approvals:

Underwriters Laboratories Inc.: meets UL873.
NEMA2
IP54 with/ eatherproof Kit (see Accessories).

Accessories:

201391 Shaft Adapter for 3/8 in. round or square shaft.
32002935-001 ML7999 Weatherproof Kit.
32003167-001 Shaft Adapter for 5/16 in. round or square shaft.
32003168-001 Shaft Adapter for 3/4 in. diameter round shaft.
32003168-002 Shaft Adapter for 5/8 in. diameter round shaft.
32003168-003 Shaft Adapter for 9/16 in. diameter round shaft.
32003396-001 V51 Mounting Bracket for 1-1/2 in. and 2 in. valves.
32003396-002 V51 Mounting Bracket for 2-1/2 in., 3 in. and 4 in. valves.

ORDERING INFORMATION

When purchasing replacement and modernization products from your TRADELINE® wholesaler or distributor, refer to the TRADELINE® Catalog or price sheets for complete ordering number.

If you have additional questions, need further information, or would like to comment on our products or services, please write or phone:

1. Your local Home and Building Control Sales Office (check white pages of your phone directory).
2. Home and Building Control Customer Logistics
Honeywell Inc., 1885 Douglas Drive North
Minneapolis, Minnesota 55422-4386 (612) 951-1000

In Canada—Honeywell Limited/Honeywell Limitée, 155 Gordon Baker Road, North York, Ontario M2H 3N7.

International Sales and Service Offices in all principal cities of the world. Manufacturing in Australia, Canada, Finland, France, Germany, Japan, Mexico, Netherlands, Spain, Taiwan, United Kingdom, U.S.A.

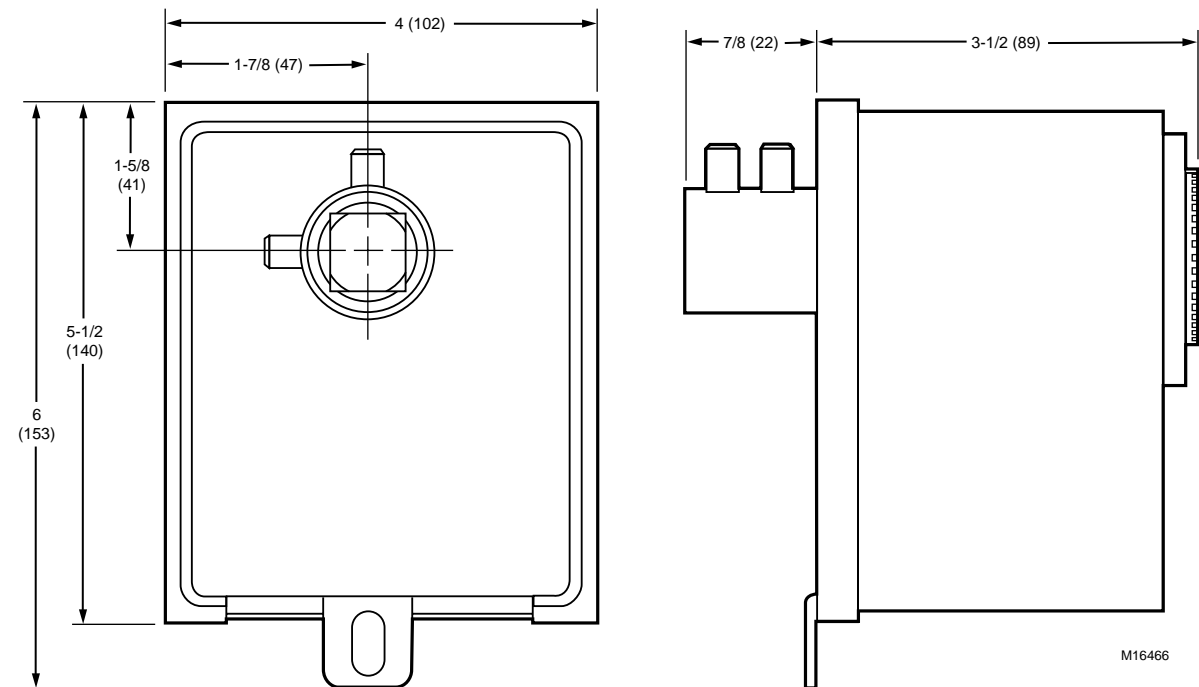

Fig. 1. ML7999 dimensions in in. (mm).

INSTALLATION

When Installing this Product...

1. Read these instructions carefully. Failure to follow them could damage the product or cause a hazardous condition.
2. Check the ratings given in the instructions and on the product to make sure the product is suitable for your application.
3. Installer must be a trained, experienced service technician.
4. After installation is complete, check out product operation as provided in these instructions.

WARNING

Fire or Explosion Hazard.
Can cause property damage, severe personal injury, or death.
Tighten the hub setscrews to a torque of 60 lb-in. (7 N·m).

WARNING

Hazardous Voltage.
Risk of electric shock that can result in death.
Disconnect power supply before installation.

Location

CAUTION

Actuator Damage Hazard.
Deteriorating vapors and acid fumes can damage the actuator metal parts.
Install actuator in areas free of acid fumes and other deteriorating vapors.

Mounting ML7999 Actuator

The actuator mounts on a 1/2 in. horizontal or vertical shaft. Using the self-centering shaft reduction piece (included), the actuator can be mounted on a 5/16 in. or a 3/8 in. shaft.

CAUTION

Equipment Damage Hazard.
Lateral forces on actuator hub will damage actuator.
Ensure actuator is mounted with shaft centered in actuator hub.

1. Place the actuator over the shaft, see Fig. 2.
2. Position and seat the actuator.
3. Rotate the shaft to match the actuator position.
4. Install the mounting bracket accessory (not included), if needed. See Fig. 3.
5. Partially tighten hub setscrews to ensure actuator seats firmly against mounting bracket with shaft centered in hub.
6. Tighten the anti-rotation bolt to the torque recommendation for the selected bolt/nut.
7. Tighten the hub setscrews against the shaft to a torque of 60 lb-in.

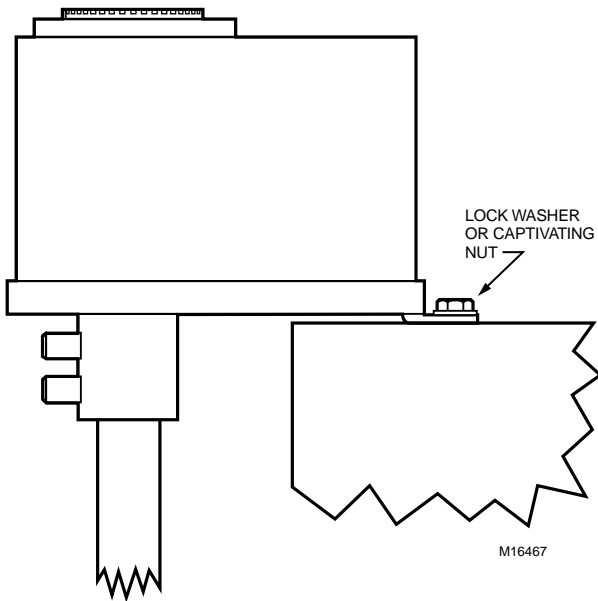

Fig. 2. Mounting ML7999.

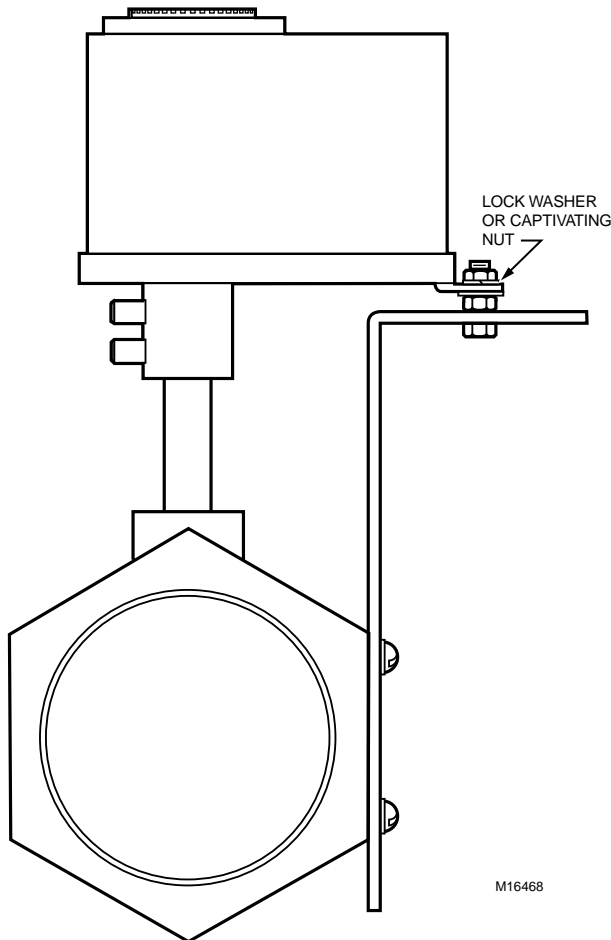

Fig. 3. Mounting ML7999 with mounting bracket accessory.

WIRING

⚠️ WARNING

Hazardous Voltage.
Risk of electric shock that can result in death.
Disconnect power supply before installation.

All wiring must comply with local electrical codes, ordinances and regulations. The ML7999 is designed for use with a Class 2 power supply for low-voltage. Voltage and frequency of the transformer must correspond with the characteristics of both the actuator and the power supply.

Preparation

Use OEM-supplied 1/2 in. conduit connectors in the low- and line- voltage base openings; the motor has separate line- and low-voltage wiring compartments.

Wiring Procedures

IMPORTANT

Device must be hardwired.

1. Remove the cover from the actuator.
2. Pull back the snap-locks while opening the low-voltage chamber. See Fig. 4.
3. Wire the low-voltage circuit to the R7999. See Fig. 5 for typical wiring connections.
4. Close the low-voltage chamber.
5. Wire the line-voltage circuit. See Fig. 5 for typical wiring connections.
6. Replace the cover on the actuator.

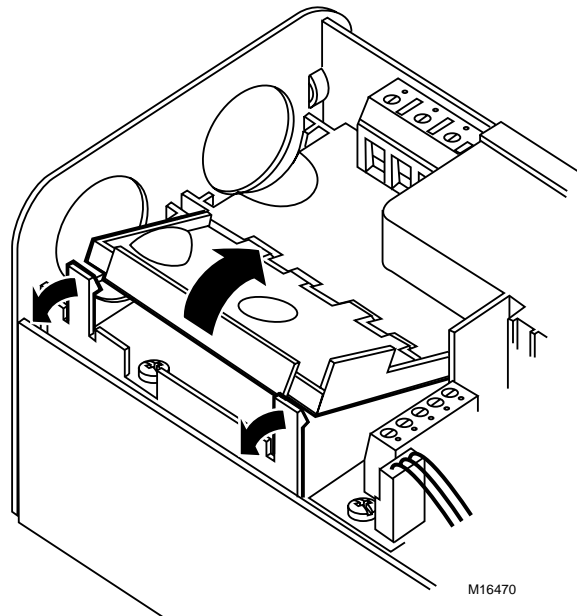

Fig. 4. Opening ML7999 low-voltage wiring chamber.

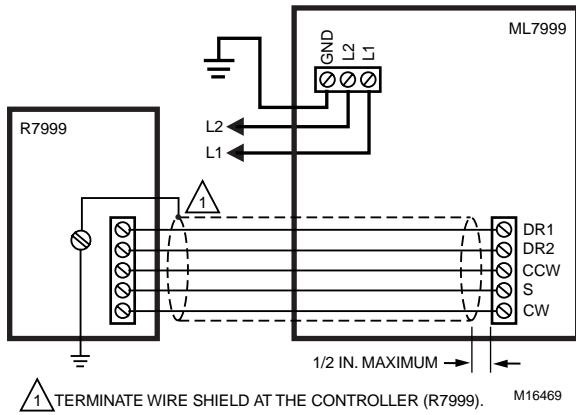

Fig. 5. Typical ML7999 wiring.

The actuator has a position indicator that shows shaft position. As the indicator moves with the shaft, it provides an angular representation of the shaft position.

IMPORTANT

When the cover is removed and replaced, the position indicator will not operate until manually rotated clockwise to engage it. An audible click indicates the position indicator is engaged.

NOTE: While installing the actuator, the hub can be manually driven using the pushbuttons located under the cover. The buttons are labeled CW and CCW. To use them, the only required wiring connections are L1, L2, and GND. However, after the device is installed and wired to the R7999, do not use these buttons for anything but troubleshooting.

OPERATION

ML7999A Universal Parallel-Positioning Actuator is designed to operate combustion air dampers, butterfly gas valves, oil modulation valves, and flue gas recirculation systems requiring up to 100 lb-in. torque. An R7999 controller operates the ML7999.

Password Protection (ID Signal)

Before using the actuator, set the ID signal must be set. See the software interface instructions for details. After this signal is set, the R7999 sends the signal to operate the actuator. Until the appropriate ID signal is sent, the actuator is offline and responds only to its own ID signal. (See Table 1.)

Table 1. On-Board LED Indications.

LED	Online	Configured	Meaning	Notes
Fast Blink	No	Yes	Awaiting ID signal.	Responds only to ID signal.
Slow Blink	Yes	Yes	ID signal recognized.	Monitors signals for operation or offline commands.
Steady On	No	No	Actuator has failed.	Return actuator to factory.

CHECKOUT AND TROUBLESHOOTING

Refer to the R7999 literature (form 66-1120) for system checkout.

Troubleshooting

If the actuator does not operate properly during Checkout, perform the following troubleshooting steps. Perform these steps before replacing the actuator:

1. Check the actuator label to make sure the power and control signal requirements are correct for the application.
2. Check for the presence of 120-240 Vac at the actuator (L1) and (L2) connections when the actuator should be driving. If the voltage is not present or is low, check the power supply.
3. Ensure actuator stroke matches stroke of damper or valve.
 - a. Remove the cover.
 - b. Press the button labeled CW. The actuator should drive the device clockwise.
 - c. Press the button labeled CCW. The actuator should drive the device counterclockwise.
5. If the actuator operates properly, check the controller for proper output signals.
6. If the actuator does not drive, remove power, disconnect the actuator hub, and try to turn the shaft clockwise and counterclockwise. If the shaft turns freely throughout the 90-degree stroke and the actuator is installed properly, replace the actuator.
7. If the shaft does not turn freely for the full 90 degrees, check for binding. If necessary, adjust mounting to prevent binding.
8. If the device shaft does not turn freely, fix or replace the device.
9. If the device shaft turns, reconnect the actuator and wiring and drive the actuator hub clockwise and counterclockwise. If the actuator does not drive, replace the actuator.
10. If the actuator and device shaft turn freely, remount the actuator to the device according to instructions in the Installation section. Make sure the actuator does not bind and that the actuator and device are both at the same clockwise or counterclockwise end stop when assembled. Hook up the wires and repeat the Checkout procedures. Troubleshoot if necessary.

Home and Building Control

Honeywell Inc.
Honeywell Plaza
P.O. Box 524
Minneapolis MN 55408-0524

Honeywell Latin American Region

480 Sawgrass Corporate Parkway
Suite 200
Sunrise FL 33325

Home and Building Control

Honeywell Limited-Honeywell Limitée
155 Gordon Baker Road
North York, Ontario
M2H 3N7

Honeywell Europe S.A.

3 Avenue du Bourget
1140 Brussels
Belgium

Honeywell Asia Pacific Inc.

Room 3213-3225
Sun Hung Kai Centre
No. 30 Harbour Road
Wanchai
Hong Kong

Honeywell

